

decomposition reactions. Other reactions using different stoichiometric amounts of the reagents were carried out in the same way.

Reactions of VII.—In addition to the physical data described previously, further evidence in favor of the proposed structure for VII was obtained from solvolytic degradation experiments. Compound VII (1 g.) was stirred with sodium hydroxide (3 g.) in absolute ethanol (25 ml.) at 25° for 18 hr. in a flask attached to a vacuum system. The solid dissolved slowly, and the initial dark green color was slowly bleached during the reaction. A gas sample from above the reaction mixture was shown, by mass spectrometry, to contain triethylamine. Acidification of the reaction mixture, followed by evaporation, extraction with ethanol, and removal of the solvent, yielded an oil which showed an infrared spectrum consistent with that expected for (o-HOC₆H₄O)₃P=O (IX).

The same product (IX) was formed by treatment of VII (3.1 g.) in tetrahydrofuran (200 ml.) with concentrated hydrochloric acid (1 ml.) at 25° for 18 hr. Prolonged treatment of VII (10 g.) with methanolic 20% hydrochloric acid (300 ml.) yielded a mixture which contained triethylamine hydrochloride and catechol. The latter compound presumably was formed by hydrolysis of IX.

A mixture of VII (3.2 g.) and dry pyridine (50 ml.) was stirred at 25° for 16 hr. within a glass vacuum system. A gas sample from above the mixture was shown by mass spectrometry to contain triethylamine. When VII was dissolved in hot pyridine, exposed to the atmosphere, triethylamine evolution was accompanied by hydrolysis. Phosphorus nuclear magnetic resonance spectra showed peaks at -16 and -1 p.p.m. which were attributed to a covalent phosphate structure. Isolation of the product by removal of the pyridine yielded an oil, which showed an infrared spectrum identical with that of IX.

Compound VII (3 g.) was dissolved in hot dimethylformamide (50 ml., dried over MgSO₄), from which VII could be recovered when the solution was cooled rapidly. More prolonged heating under anhydrous conditions caused evolution of triethylamine. Removal of the solvent yielded an oil which showed an infrared spectrum consistent with that expected for VIII. Treatment of the dimethylformamide solution of VIII with triethylamine yielded VII. If the solution of VII or VIII in dimethylformamide was heated while exposed to the atmosphere or in the presence of water, VII could not be recovered by treatment with triethylamine. Phosphorus nuclear magnetic resonance measurements of this solution showed one strong peak at -16 p.p.m. and one weaker at -1 p.p.m., which was consistent with a covalent phosphate structure. Removal of the solvent yielded a glass which showed an infrared spectrum consistent with structure IX.

Reaction of Phosphonitrilic Chloride Tetramer with Catechol and Triethylamine.—A solution of catechol (26.4 g., 0.24 mole) and triethylamine (48.48 g., 0.48 mole) in tetrahydrofuran (200 ml.) was added dropwise to a stirred solution of phosphonitrilic chloride tetramer (27.84 g., 0.06 mole) in tetrahydrofuran (1000 ml.). A white mist of triethylamine hydrochloride formed immediately above the reaction mixture, which was stirred at 25° for 48 hr. The white precipitate was then filtered off, washed with tetrahydrofuran, and dried. Treatment with water removed triethylamine hydrochloride (66.3 g.) from the solid. The residue was subjected to a prolonged extraction with boiling toluene, but no soluble material was isolated. An infrared spectrum of the residue showed it to be VII (13.7 g.). The original tetrahydrofuran filtrate was evaporated to dryness, but subsequent extractions of the residue (28 g.) with boiling benzene and boiling toluene served only to render the material insoluble in all solvents. Infrared spectra of this material indicated that it was a partially substituted, cross-linked polymer. *Anal.* Found: C, 36.29; H, 6.10; N, 9.42; P, 13.57; Cl, 8.37.

Reaction of Phosphonitrilic Chloride Polymer with Catechol and Triethylamine. A. Preparation of (NPCl₂)_n Polymer.—Phosphonitrilic chloride trimer (I) was heated in an evacuated, thick-walled glass tube for 5 hr. at 300° in the absence of a catalyst, or for 30 hr. at 200° in the presence of 1% benzoic acid. The rubbery product was then extracted with toluene to remove unchanged starting material and was subdivided into small particles prior to reaction.

B. Reaction of Polymer.—A solution of triethylamine (175 g.) and catechol (95 g.) in tetrahydrofuran was added dropwise to a stirred suspension of phosphonitrilic chloride elastomer (100 g., swelled with 200 g. of toluene) in tetrahydrofuran (1 l.). The mixture was stirred at 25° for 7 days and the solid was filtered off, washed with toluene and tetrahydrofuran, and dried. The filtrate was evaporated to leave a brown oil (9 g.). The solid obtained by filtration (425 g.) was washed with a large excess of water and with methanol (2 l.) and was dried (132 g.). An infrared spectrum of this product was identical with that of VII.

Acknowledgments.—The author wishes to thank Dr. J. E. Lancaster and Mrs. M. Neglia for the n.m.r. data, Mr. A. H. Struck for the mass spectrometry measurements, Mr. N. B. Colthup and Mr. J. Koren for the spectra, Dr. J. H. Deonarine and associates for microanalyses, and Dr. L. A. Siegel for the X-ray diffraction results. Discussions with Dr. M. Grayson and Dr. R. F. Hudson are also acknowledged.

[CONTRIBUTION FROM THE CHEMISTRY DEPARTMENT, VANDERBILT UNIVERSITY, NASHVILLE, TENNESSEE 37203]

Electron Exchange Kinetics of the NO₃ Free Radical in Solution¹

BY T. W. MARTIN,² R. E. RUMMEL, AND R. C. GROSS

RECEIVED FEBRUARY 17, 1964

The NO₃ free radical can be generated photochemically in aqueous 6 M nitric acid by the primary electron-exchange reaction, Ce^{IV}NO₃⁻ + hν $\xrightarrow{I_a}$ Ce(III) + NO₃. Possible secondary reactions between NO₃ and added solutes are found to be in competition with the fast spontaneous bimolecular electron back-exchange process, NO₃ + Ce(III) $\xrightarrow{k_2}$ Ce^{IV}NO₃⁻. By means of an improved flash kinetic method which features a simplified photolysis lamp design and a new ignitron firing technique, we have measured $k_2 = (1.70 \pm 0.04) \times 10^6$ M⁻¹ sec.⁻¹ at 23° with good precision. The back-exchange process is only slightly temperature dependent, with an apparent activation energy estimated to be approximately 1.0 ± 0.2 kcal./mole over the interval from 23 to 50°. An interpretation of these results and their role in explaining the slow decomposition of ceric nitrate salts in nitric acid solution is discussed.

Introduction

In an earlier note³ we have shown that the NO₃ free radical can be generated in aqueous media at room

temperature by the photolysis of ceric ammonium nitrate solutions. In contrast to the earlier methods of preparation, which are of value for studying the properties of NO₃ in either gas phase^{4,5} or frozen matrix,⁶ this photolysis technique represents not only

(1) Presented in part at the 146th National Meeting of the American Chemical Society, Denver, Colo., Jan., 1964.

(2) To whom correspondence about this paper should be sent.

(3) T. W. Martin, A. Henshall, and R. C. Gross, *J. Am. Chem. Soc.*, **85**, 113 (1963).

(4) E. J. Jones and O. R. Wulf, *J. Chem. Phys.*, **5**, 873 (1937).

(5) G. Schott and N. Davidson, *J. Am. Chem. Soc.*, **80**, 1841 (1958).

(6) W. B. De More and N. Davidson, *ibid.*, **81**, 5869 (1959).

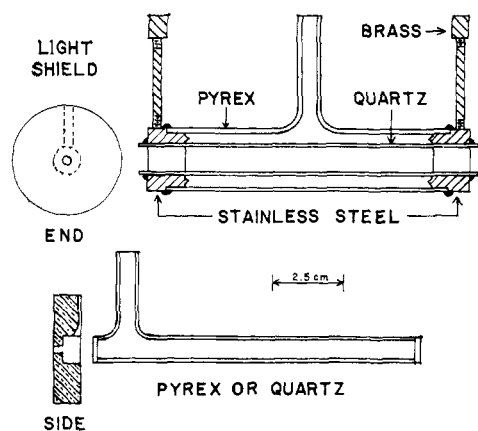
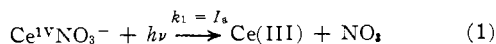

Fig. 1.—The photolysis lamp and sample cell (each to scale).

a new chemical way to produce NO_3 but also an easy method of introducing it homogeneously into solution at a controlled rate.

We previously suggested that the primary photochemical process for generating the NO_3 radical by this method could be represented as



whereby the absorbed photon initiates an intramolecular oxidation-reduction reaction in the excited state of the absorbing species by an electron exchange between one of the nitrate ligand ions and its associated cerium(IV) atom. The process results in the formation of a cerium(III) species and the short-lived NO_3 radical. The NO_3 solution absorption spectrum³ is found to exhibit three characteristic and prominent peaks with maxima at 598, 635, and 671 $\text{m}\mu$. Following its formation by reaction 1, we have found that the NO_3 radical can either react with other components in solution or must decay away by a fast spontaneous bimolecular electron back-exchange reaction (2), which is essentially the reverse of the primary process except that the energy change involved is purely thermal in character.

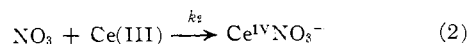

The main purpose of this paper is to prove reaction 2, and by so doing provide strong evidence that reaction 1 is the correct primary process. To accomplish this objective, the specific rate for reaction 2 was measured accurately in aqueous solutions containing $10^{-3} M$ ceric ammonium nitrate in 6 M nitric acid. This particular solvent system was chosen to restrict possible ambiguity in the primary process, because previous spectrophotometric and chemical work⁷ has shown that the hexanitratocerate ion, $\text{Ce}(\text{NO}_3)_6^{-2}$, is the only important ceric species present in this medium. The rate of reaction of the NO_3 radical was observed by monitoring its absorption transient at 635 $\text{m}\mu$ with a suitable flash spectroscopic apparatus.

Experimental

Chemicals.—A stock solution was prepared from certified grade ceric ammonium nitrate (G. F. Smith Chemical Co.) by weighing accurately 0.5 g. of this primary standard, previously dried at 85° for 1 hr., into a 100-ml. volumetric flask and diluting to volume with standard 6.0 M nitric acid solvent. Similarly, a stock solution of reagent grade cerous ammonium nitrate (G. F. Smith Chemical Co.) was made by weighing out the approximate

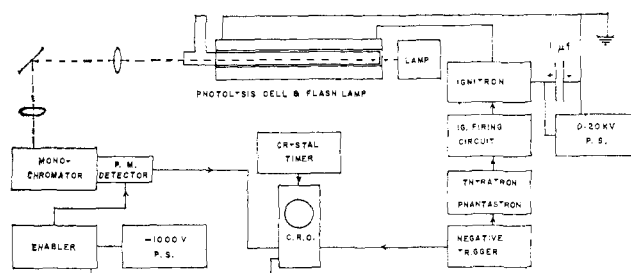

Fig. 2.—Block diagram (not to scale) of the flash kinetic apparatus.

amount of hydrated salt and dissolving it in the same solvent. The exact concentration of this $\text{Ce}(\text{III})$ solution was determined gravimetrically by pipetting an aliquot into a platinum crucible, evaporating carefully, and then firing for 15 min. over a Fisher burner before cooling and weighing the residue as CeO_2 .

Most of the sample solutions to be irradiated were made up by delivering appropriate aliquots of the $\text{Ce}(\text{IV})$ and $\text{Ce}(\text{III})$ stock solutions into a 100-ml. volumetric flask and diluting to the mark with 6.0 M nitric acid solvent. When $\text{Ce}(\text{IV})$ samples were diluted to approximately $10^{-3} M$, they were found to be slightly unstable. Hence, only freshly prepared stock and diluted solutions were used. In one set of experiments, aliquots of glacial acetic acid (Baker Chemical Co.) were added to the sample solutions together with sufficient concentrated nitric acid (Baker and Adamson Chemical Co.) to maintain the final solutions at 6.0 M in nitric acid.

Portions of each of the sample solutions were introduced into a quartz sample cell and then placed inside the photolysis flash lamp for irradiation (see Fig. 1). Only one flash was made on each cell filling. No attempt was made to degas the solutions of dissolved oxygen, because preliminary test experiments proved that such a precaution was not necessary.

Optical System.—The flash photolysis lamp in Fig. 1 is a new design which features a simple rugged construction without difficult glassblowing, excellent sample irradiation geometry, and reproducible flash characteristics. It consists simply of two massive Type 316 stainless steel end pieces slip-fitted to an outer Pyrex jacket and an inner quartz tube. All pieces of the lamp were held together for this work with Apiezon W wax seals (indicated but not labeled in Fig. 1) covering only the outside junctions where the glass parts come in contact with the metal. Thus, the sealant is easy to apply and is not exposed to either the electrical or the light discharge during the flash. An epoxy resin sealant must be employed if the lamp is to be used above 50°. After assembly, the Pyrex outer jacket is smoked by burning magnesium ribbon to coat the outside surface with a heavy layer of magnesium oxide which maximizes the lamp intensity. When the lamp is completely assembled, it is filled with pure oxygen at 40 torr and fired routinely at 15 kv. A typical undamped flash profile taken at 450 $\text{m}\mu$, which lies in the spectral region of greatest discharge intensity, shows clearly that the flash pulse is so concentrated in the two initial sharp peaks that all kinetic runs in this study appear to start at an extrapolated time corresponding to 8–10 μsec . after initial lamp breakdown. It is also seen by the profile that the 99% decay time of our present flash lamp circuit is approximately 65 μsec . The flash lamp's large end piece electrodes help to minimize sputtering and the tapered triangular annulus on their inside surface, which aids initial breakdown, shows almost no wear after hundreds of flashes. In conditioning a new lamp, it is first pumped out and then flashed repeatedly at reduced pressure and voltage. During each series of experiments, it is pumped out and refilled with fresh oxygen every 30 min. to assure uniformity in successive flashes.

The general arrangement of the rest of the optical system and its relation to the associated electronic apparatus is shown in the nonscale drawing of Fig. 2. The steady-state analyzing lamp used was a 6 v. d.c. General Electric 100-w. microscope illuminator bulb with an SR-6A filament drawing 18 amp. from a lead storage battery. Its light beam was directed down the axis of the sample cell by means of a black micarta tube, 8 cm. long and 0.6 cm. i.d. (not shown), leading from the exit port of the analyzing lamp housing to the front of the cell window. The transmitted light emerging from the cell was deflected 90° and focused onto the entrance slit of a Bausch and Lomb (250-

(7) A. Henshall, Ph.D. Thesis, Vanderbilt University, 1963.

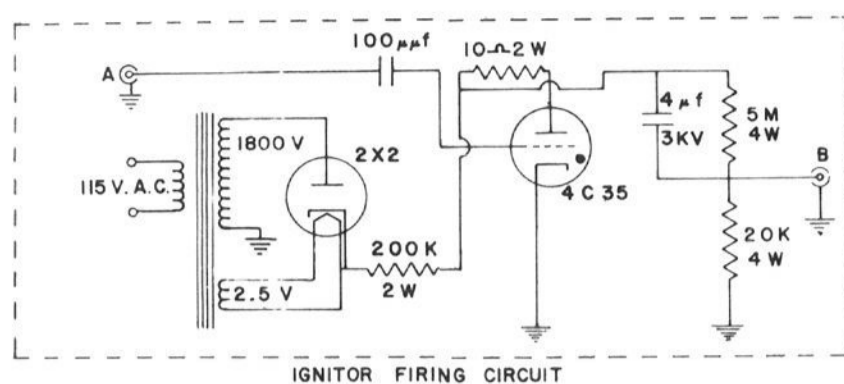

Fig. 3.—The ignitor firing circuit.

mm. model) grating monochromator by means of two suitable quartz lenses and a front-surfaced mirror. The mirror was used only for laboratory convenience in diverting the beam from entering the Bausch and Lomb Model 11 spectrograph employed in our previous NO₃ absorption spectrum study.³ Both the entrance and exit slits of the monochromator were set at 3.5 mm. to monitor the most sensitive $635 \pm 6 \text{ m}\mu$ band of the NO₃ spectrum. A Corning filter (No. CS-0-51, not shown) was placed in front of the monochromator lens to eliminate any possible second-order interference with the 635-m μ band.

Electronic Apparatus.—Our use of a high voltage ignitron tube to ensure reproducible firing of the photolysis lamp has not been reported previously in chemical flash kinetic studies. With this technique it is possible to start each kinetic run with respect to the starting time of the photolysis flash to better than $\pm 0.5 \mu\text{sec.}$ over a wide flash energy range.

The firing sequence for each experimental run is initiated manually by closing a microswitch on the negative trigger panel (Fig. 2). This action starts a biased flip-flop circuit whose output is differentiated and clipped to produce a sharp -75-v. peak trigger pulse with a $2\text{-}\mu\text{sec.}$ rise time. The negative trigger pulse is fed simultaneously to start both the Tetrax 555 dual-beam oscilloscope and the phantastron delay circuit.

The phantastron-thyratron panel in Fig. 2 is similar to that described by Claesson and Lindquist⁸ except for several significant changes in the 884 thyratron stage. We have removed the induction coil from their 884 plate circuit, the negative side of the $2\text{-}\mu\text{f.}$ capacitor was grounded, and the 884 cathode was connected directly to junction A of the ignitor firing circuit given in Fig. 3. Thus, when the 884 is triggered by a delayed pulse from the phantastron, a $+190\text{-v.}, 2\text{-}\mu\text{sec.}$ rise-time pulse is generated to provide a trigger for the 4C35 (Kuthe Lab.) hydrogen thyratron. The 4C35 is of necessity a high voltage tube, which on breakdown produces a fast, large power pulse in excess of 1500 v. The pulse is delivered at junction B in less than $0.5 \mu\text{sec.}$ to the grounded primary of a 1:1 pulse transformer (not shown) whose well-insulated and grounded secondary is connected to the ignitor terminal of a GL-7703 (General Electric) mercury ignitron tube. The ignitron is positioned in series with the photolysis lamp and a single $1\text{-}\mu\text{f.}$ high voltage capacitor charged to 15 kv. by a converted LORAN power supply. The ignitron functions as a rapid high voltage switch which induces instantaneous breakdown of the flash lamp. Although this method of firing flash lamps requires slightly more expensive circuitry than the more usual methods, it is so remarkably stable and dependable that a series of flashes can be reproduced both in time to better than $\pm 0.5 \mu\text{sec.}$ and in intensity to better than $\pm 1\%$. The same ignitron technique is a more versatile device than we have illustrated in this work, because it is applicable to much higher flash energies, *e.g.*, one GL-7703 can handle up to 10^5 joules in a single pulse. Although the phantastron delay is easily variable, it was found convenient for this work to fire the photolysis lamp $67 \mu\text{sec.}$ after negative trigger.

In order to coordinate the detection of the NO₃ radical with the photolysis flash, the following procedure was used. The negative trigger, fed to the oscilloscope through a P-6000 (10X) voltage attenuator, started time base A which was set to send a delayed signal to switch on time base B just $120 \mu\text{sec.}$ after receiving the negative trigger. Time base B then starts the sweep of both oscilloscope beams simultaneously and at the same instant sends a $+30\text{-v.}$ pulse to turn on the enabler circuit which has been described elsewhere.⁹ Thus, time zero of the oscillo-

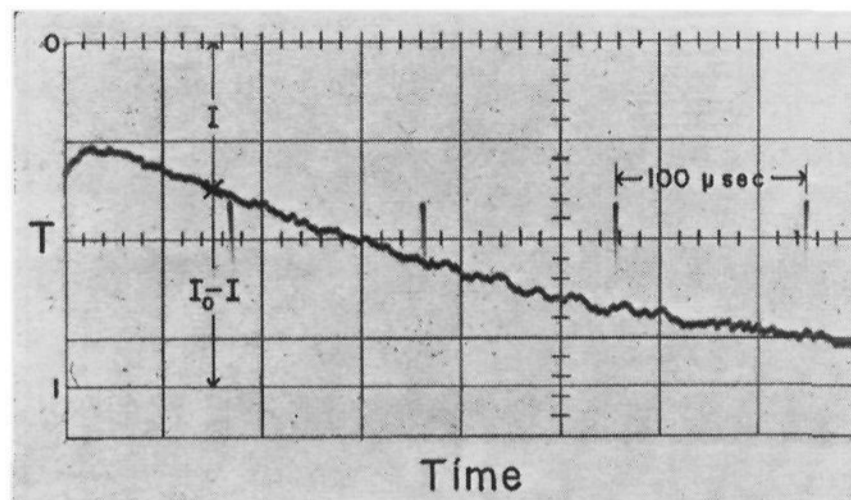

Fig. 4.—Typical NO₃ decay curve measured at $635 \text{ m}\mu$: initial sample solution, $1.01 \times 10^{-3} \text{ M Ce(IV)}$ and $2.94 \times 10^{-3} \text{ M Ce(III)}$ in 6.0 M nitric acid at 23° ; oscilloscope vertical sensitivity, 2 v./cm.

scope traces is equivalent to the time of enabling. The enabler circuit, normally floating at -660 v. , functions to protect the sensitive 1P28 (R.C.A.) photomultiplier by activating the photocathode to -750 v. only at the proper time for recording the desired data. Using the selected time delays for the phantastron and time base A given above, the photomultiplier was enabled $53 \mu\text{sec.}$ after the start of the photolysis flash to allow sufficient time for the detection circuit to become equilibrated to record the entire decay curve reliably after scattered light from the flash no longer interferes with the absorbance changes in the analyzing light beam. The 1P28 is mounted in a special housing together with a 6AU6 cathode follower circuit behind the exit slit of the monochromator. The cathode follower amplifies the power of the original 1P28 signal sufficiently to prevent cable attenuation so that the time dependent absorbance changes are reproduced reliably on the lower trace of the oscilloscope. A set of precise time markers from a Tetrax Type RM 181 temperature-controlled oscillator is displayed for reference on the upper trace in order to calibrate the time axis of the NO₃ decay curve. Vertical deflections of the lower trace, which are directly related to optical transmittance, were calibrated for linearity by inserting known neutral density filters into the steady-state analyzing beam and adjusting the observed d.c. level response to within $\pm 2\%$ by appropriately changing monochromator slits and photocathode voltages.

Photographic Methods.—We have found that a 35-mm. Leica I-f camera fitted with a Visoflex-II attachment, a 65-mm. Elmar $f 3.5$ lens, and utilizing Tri-X (Eastman Kodak Co.) film makes an inexpensive and versatile oscilloscope camera for quantitative flash work. The processed negative on each data run was analyzed by making an accurate print enlarged more than eightfold using a 50-mm., $f 4.0$ Schneider Componon lens. Before exposing to make each print, a transparent plastic millimeter grid was laid on top of the print paper and oriented squarely with respect to the oscilloscope image. Thus, a fine millimeter grid system appeared on each final print for more convenient and accurate measurement of the rate data.

Results

A representative NO₃ decay curve, as recorded by the oscilloscope camera, is presented in Fig. 4 with appropriate labels to show how the transmittance ($T = I/I_0$) of the radical as a function of oscilloscope time was measured in this study. Standard $100\text{-}\mu\text{sec.}$ time markers on the upper trace can also be seen in this figure. With the vertical response of the oscilloscope previously calibrated and the sample cell in place, the no-signal d.c. level corresponding to $T = 0$ was established by closing a shutter on the analyzing lamp housing and positioning the lower oscilloscope sweep to coincide with the labeled grid line. The full-light d.c. level ($T = 1$) was then determined from the average of its position on two photographs of the sweep, one of which was taken just prior to and the other just after each flash experiment. All transmittance measure-

(8) S. Claesson and L. Lindquist, *Arkiv Kemi*, **11**, 535 (1957).

(9) R. J. Charlson, H. Harrison, and R. Hardwick, *Rev. Sci. Instr.*, **31**, 46 (1960).

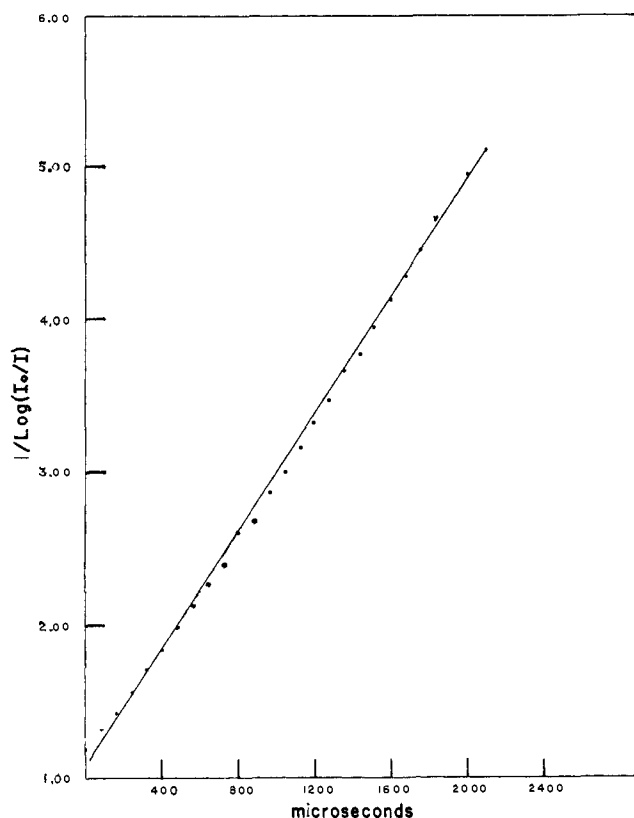

Fig. 5.—Second-order kinetic plot of average NO_3 decay data: initial sample solution, $1.01 \times 10^{-3} M$ Ce(IV) in $6.0 M$ nitric acid at 23° .

ments were then converted to absorbance values of the NO_3 radical at selected time intervals to analyze the kinetics of the decay process under various experimental conditions. However, because of scattered flash light, no reliable absorbance measurements could be made until about $30 \mu\text{sec.}$ after the start of the oscilloscope sweeps. For a given quantitative experiment, the measured absorbances at identical oscilloscope times from at least five separate runs (each taken by flashing a fresh portion of the sample solution) were averaged together. Conventional plots of these average absorbance values as a function of time were used to calculate the rate constants reported in this study.

In solutions containing only $1.01 \times 10^{-3} M$ ceric ammonium nitrate in $6.0 M$ nitric acid, the average of eight flash runs yielded the second-order decay curve shown in Fig. 5. These data proved that the NO_3 radical decays neither by a unimolecular decomposition nor by a pseudo-first-order attack on the excess aqueous solvent. Rather, they show that the radical must disappear bimolecularly either through a radical dimerization process or by means of reaction 2. To distinguish between the latter two possibilities, increasing amounts of cerous ammonium nitrate were added to the solution. On doing so, the observed decays were then found to change over to pseudo-first-order kinetics. The results of these experiments are presented in Fig. 6. The excellent precision of these data is revealed by the fact that each of these curves can be extrapolated back to define a common intersection at a time corresponding to $8\text{--}10 \mu\text{sec.}$ after initial flash lamp breakdown which we know from flash profile studies to be the time of maximum flash intensity.

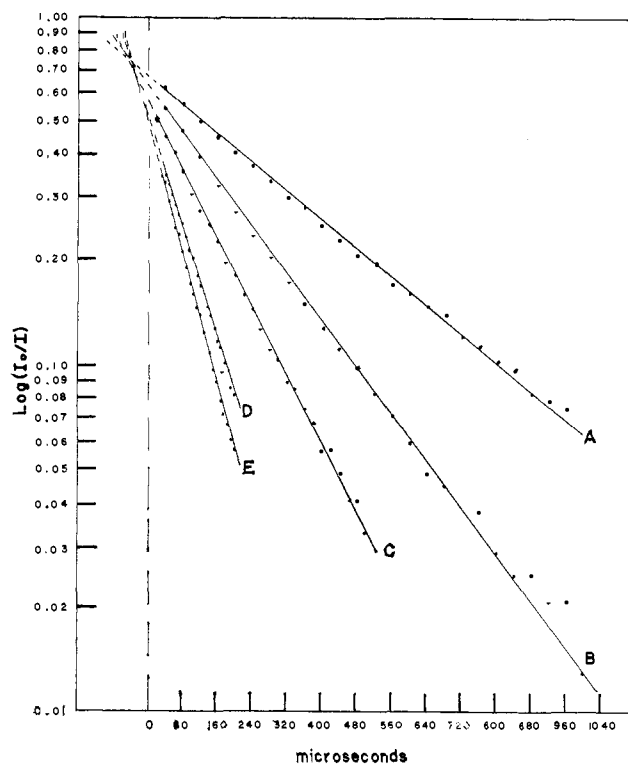

Fig. 6.—Pseudo-first-order kinetic plots of average NO_3 decay data showing effect of varying initial Ce(III) in the sample. The specific sample composition used and the kinetic analysis for each curve are summarized in Table I.

These findings show conclusively that the NO_3 radical under these conditions decays exclusively by reaction 2 which is described by the simple rate expression

$$-d[\text{NO}_3]/dt = k_2[\text{Ce(III)}][\text{NO}_3] = k'[\text{NO}_3]$$

where $k' = k_2[\text{Ce(III)}]$ is the pseudo-first-order constant observed when a sufficient quantity of cerous ammonium nitrate is added to the sample before flash. These results are consistent with our contention that reaction 1 is the correct primary photochemical process for the hexanitrate Ce(IV) species in aqueous $6 M$ nitric acid. That this primary process depends only on the Ce(IV) complex and not on the NH_4^+ cations added with the ceric ammonium salt was demonstrated by obtaining the same kinetic results using ceric potassium nitrate.

By measuring k' at various initial Ce(III) concentrations, it was possible to estimate k_2 . These calculations, based on the data illustrated in Fig. 6, are summarized in Table I. Because of the resolving time of the present flash apparatus, we were limited to studying reactions with half-lives $> 50 \mu\text{sec.}$ Therefore, it was not possible to add sufficient initial Ce(III) concentration before a flash to avoid the necessity of correcting for the Ce(III) concentration contributed during the flash by the primary process. By an iterative calculation to minimize the dispersion in the corrected k_2 values from all five curves, the best experimental fit was obtained by assuming that on the average $40 \pm 2\%$ of the initial Ce(IV) was converted instantaneously to Ce(III) in each flash run. This led to an average corrected value of $k_2 = (1.70 \pm 0.04) \times 10^6 M^{-1} \text{sec.}^{-1}$ at 23° for the back-exchange reaction.

TABLE I
ANALYSIS^a OF FIRST-ORDER DATA FROM FIG. 1

Curve	Ce(III) × 10 ³ M (before flash)	Half-life, μsec.	k' × 10 ⁻³ , sec. ⁻¹	k ₂ × 10 ⁻⁶ , uncorrected, ^b M ⁻¹ sec. ⁻¹	k ₂ × 10 ⁻⁶ , corrected, ^c M ⁻¹ sec. ⁻¹
A	0.98	291	2.38	2.43	1.72
B	1.96	180	3.85	1.96	1.63
C	2.94	123	5.63	1.91	1.69
D	4.90	75	9.24	1.89	1.74
E	5.88	64	10.83	1.84	1.72
Av. k ₂ = (1.70 ± 0.04) × 10 ⁶ M ⁻¹ sec. ⁻¹					

^a Sample conditions: 1.01 × 10⁻³ M ceric ammonium nitrate in aqueous 6.0 M nitric acid at 23° with fixed amounts of cerous ammonium nitrate added before flash. ^b Calculated without correcting for Ce(III) contributed by the primary process. ^c Calculated by assuming 40% of original Ce(IV) is converted to Ce(III) in flash.

After succeeding in measuring *k*₂ by selectively monitoring the rate of decay of the NO₃ radical, we further attempted to verify reaction 2 by observing the specific rate of change in Ce(IV) concentration after flash. The efficiency of our monochromator grating and the large absorption by nitrate ion in this system limited us to work on the long wave length side (3500–4300 Å.) of the Ce(IV) absorption band. Although we were able to find growth curves for a Ce(III) → Ce(IV) transition in the approximate half-life region predicted by our NO₃ data, the changes were too small for accurate measurement. We explain this unexpected result by assuming that the absorption by NO₃ radical in this spectral region is almost able to compensate in absorbance for the amount of Ce(IV) bleached in the flash. Hence, the changes we observed were much smaller than expected.

In order to check if there was a noticeable effect of temperature on *k*₂, a series of six pseudo-first-order runs was made at 50 ± 2° with the same sample composition used to obtain curve C in Fig. 6. Treating the data in the usual way and comparing with the curve at 23° it was found that there was a small, but definite, increase in the rate over this 27° temperature interval corresponding to an Arrhenius activation energy of 1.0 ± 0.2 kcal./mole.

Partial evidence for another very interesting electron-transfer reaction was discovered in the course of this investigation. On exposing the same dilute Ce(IV) sample solution to many successive flashes or by letting these samples stand for several days in the dark, it was found that there was some permanent bleaching of the initial Ce(IV) concentration. We believe that these observations could all be explained by postulating that a slow, spontaneous electron-transfer process (reaction 3) takes place between the Ce(IV) complex and the water solvent with a nitrate ligand ion acting as the bridging group.

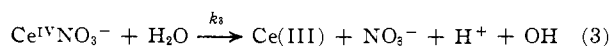

This reaction is made quite irreversible and its bleaching effect is further enhanced by the fact that both the intermediate hydroxyl radicals produced in (3), and any hydrogen peroxide which may be derived from their dimerization, are rapidly oxidized to molecular oxygen at the expense of additional Ce(IV) present in excess in the system. Since we postulated that the

reaction is slow and does not involve the NO₃ radical, it could not then interfere with our measurement of *k*₂. The fact that the rate of the bleaching reaction is apparently accelerated by the flash could be explained as the result of the extra thermal energy localized in the solvation shell of the Ce(IV) complex by the spontaneous back-exchange process (reaction 2). However, we think it probable that reaction 3 is actually a two-step process: the first being the thermal equilibrium production of a trace amount of NO₃ radical by (3a), the second being a slow, rate-determining hydrogen abstraction process (3b) generating the hydroxyl

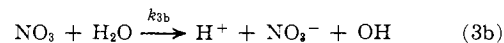

radical. This two-step mechanism accounts for the slow decay of Ce(IV) solutions in the dark by means of the tiny steady-state concentration of NO₃ radical presumably always present in the system. It also better explains the increased rate of (3) on exposure of the system to light, because not only is the energy argument stated above still operating but also the increased concentration of NO₃ radicals during flash increases the relative importance of (3b) over its dark steady-state value. However, even at flash intensities, evidently *k*_{3b}[H₂O] << *k*₂[Ce(III)], so that the occurrence of this slow competing reaction for NO₃ radical did not interfere with our measurement of *k*₂.

Although postulated process 3b is not a significant competing reaction for NO₃ in 6 M nitric acid, we were able to show that it is feasible to add another solute to this medium which is able to compete far better than water in consuming NO₃ radicals generated during flash photolysis. For example, because of another concurrent investigation¹⁰ into the reactions of NO₃ radical with glacial acetic acid, we tested the effect of adding acetic acid to our sample solutions. The flash kinetics were easily shown to be related to the concentration of acetic acid added as were the total yields of carbon dioxide and methane isolated from the photolyzed system. In going from 0 to 10 M acetic acid added, the NO₃ decay curves changed from strict second-order, dependent only on reaction 2, to good pseudo-first-order kinetics where reaction 4 is the dominant process. An analysis of the kinetic

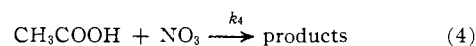

data gave a good estimate of *k*₄ = (2.3 ± 0.2) × 10² M⁻¹ sec.⁻¹ at 23° in this mixed solvent system. The products produced by reaction 4 will be discussed at length in a forthcoming paper.¹⁰

Discussion

By the procedures outlined above, our determination of *k*₂ = (1.70 ± 0.04) × 10⁶ M⁻¹ sec.⁻¹ at 23° represents the first measurement of an electron-transfer reaction between a neutral free-radical species and an inorganic ion. It is obvious from the magnitude of *k*₂ that this electron-transfer process is far from being diffusion-controlled. Since the apparent activation energy is negligibly small, it would appear that there is not a severe energy barrier in reorganizing the Ce(III)–NO₃ system to the final Ce(IV) complex. Hence,

(10) T. W. Martin, J. M. Burk, and A. Henshall, unpublished work.

we are forced to conclude that some kind of special steric factor is operating here which decreases the probability of exchange. An ordinary but not very precise explanation is that the exact orientation of the NO_3 radical with respect to the Ce(III) species is extremely critical. Another intriguing possibility is that some sort of interaction either between the NO_3^- ion and the NO_3 radical or between the NO_3^- ion and the ligand atmosphere of the Ce(III) species is influencing the number of effective collisions between Ce(III) and NO_3 , because we have found¹¹ that the magnitude of k_2 is related to the concentration of NO_3^- ion in this system.

From the well-established oxidation potential of -1.6 v. for the couple, $\text{Ce(III)} \rightarrow \text{Ce(IV)} + e^-$, in 6 M nitric acid,¹² it is possible to predict that -1.6 v. is the upper limit of the oxidation potential for the solution couple, $\text{NO}_3^- \rightarrow \text{NO}_3 + e^-$, because reaction 2, in which Ce(III) is oxidized by NO_3 radical, was found to occur spontaneously. Since the $\text{Ce(IV)} \rightarrow \text{Ce(III)}$ potential lies very close to the standard oxidation potential of water (accepted to be about -1.7 v. in many electrolytes) it is not surprising that we observed a slow permanent bleaching of the yellow Ce(IV) in this system. However, it is our hypothesis that ceric nitrate salts in nitric acid solution most probably decompose by a mechanism involving the formation of intermediate NO_3 radicals. We suggest that even in the dark the potential energy latent in the cerium couple tends to generate the NO_3 radical in opposition to the efficient back-exchange process 2. Together these two opposing reactions constitute the equilibrium process 3a which we would predict provides a small steady-state concentration of NO_3 in this system. Unfortunately, we are not able to do an electron spin resonance study which could possibly prove (3a). The reason for the apparent slowness of postulated reaction 3b between NO_3 radical and water cannot yet be deduced in view of the uncertainty of the electron affinity of the NO_3 radical discussed with the other thermodynamic data summarized in Table II. If the upper limit, $E(\text{NO}_3) = -96$ kcal./mole, is correct then (3b) is probably slow simply because the reaction is endoergic; conversely, should $E(\text{NO}_3)$ be more negative such that (3b) is actually exoergic, then a typical

activation energy barrier must be controlling the rate of this abstraction process. At present we tend to believe the latter is more likely, so that the enhanced rate of bleaching observed both in the dark at higher temperatures and in the presence of light is explained primarily by the increased concentration of "activated" NO_3 radicals produced under these conditions. It also follows from this analysis that the relative stability of ceric nitrate salts in aqueous nitric acid solution could be increased by adding cerous ion to favor the rate of process 2 at the expense of process 3b.

TABLE II
ESTIMATION OF HEAT OF REACTION 3b BETWEEN NO_3
RADICAL AND WATER

Reactions	ΔH_{298} , kcal./ mole	Comment and/or reference
(a) $\text{H}_2\text{O(aq)} \rightarrow \text{H}_2\text{O(g)}$	10	$\Delta H_{\text{vap}}(\text{H}_2\text{O})$
(b) $\text{H}_2\text{O(g)} \rightarrow \text{H(g)} + \text{OH(g)}$	120	^a
(c) $\text{H(g)} \rightarrow \text{H}^+(\text{g}) + e^-(\text{g})$	314	^b
(d) $\text{H}^+(\text{g)} \rightarrow \text{H}^+(\text{aq)}$	-256	^c
(e) $\text{OH(g)} \rightarrow \text{OH(aq)}$	-5	Assumed $\approx 1/2 \Delta H_{\text{cond}}(\text{H}_2\text{O})$
(f) $\text{NO}_3(\text{aq}) \rightarrow \text{NO}_3(\text{g})$	δ	Assumed similar to reverse of step e
(g) $\text{NO}_3(\text{g}) + e^-(\text{g}) \rightarrow \text{NO}_3^-(\text{g})$	< -96	The exact value of the electron affinity $E(\text{NO}_3)$ is still in doubt ^d
(h) $\text{NO}_3^-(\text{g}) \rightarrow \text{NO}_3^-(\text{aq})$	-78	^e
(3b) $\text{NO}_3(\text{aq}) + \text{H}_2\text{O(aq)} \rightarrow \text{NO}_3^-(\text{aq}) + \text{H}^+(\text{aq}) + \text{OH(aq)}$; $\Delta H_{298} < 14$ kcal./mole		

^a F. D. Rossini, *et al.*, "Selected Values of Chemical Thermodynamic Properties," National Bureau of Standards, Circular 500, U. S. Govt. Printing Office, Washington, D. C., 1952.

^b F. H. Field and J. L. Franklin, "Electron Impact Phenomena," Academic Press, Inc., New York, N. Y., 1957, p. 243. ^c W. M. Latimer, "Oxidation Potentials," 2nd Ed., Prentice-Hall, Inc., New York, N. Y., 1952, p. 22. ^d The absolute value of $E(\text{NO}_3)$ given by Morris (footnote e) is too small by at least 4 kcal. in view of the recent value of $\Delta H_{f300}(\text{NO}_3) = 17.1$ kcal./mole obtained by G. Schott and N. Davidson, *J. Am. Chem. Soc.*, **80**, 1841 (1958). Furthermore, if the difference between $E(\text{NO}_2)$ and $E(\text{NO}_3)$ from Morris' estimates has any real significance, then $E(\text{NO}_3)$ could lie between -96 and -126 kcal./mole as a result of the new experimental limit placed on $E(\text{NO}_2) < -88.1$ kcal./mole by R. K. Curran, *Phys. Rev.*, **125**, 910 (1962). ^e D. F. C. Morris, *J. Inorg. Nucl. Chem.*, **6**, 295 (1958).

Acknowledgment.—This work was entirely supported by the National Science Foundation, for which help the authors are deeply grateful. We also wish to thank D. McInturff and A. T. Sutton who each helped to design and build some of our electrical panels.

(11) T. W. Martin and R. C. Gross, unpublished results.

(12) G. F. Smith and C. A. Getz, *Anal. Chem.*, **10**, 191 (1938).